



FIRE | RESCUE | EMS

XL SKID UNIT

CRATED & SHIPPED ANYWHERE!

Engineered for Future Add-On Options
"Plug and Play"

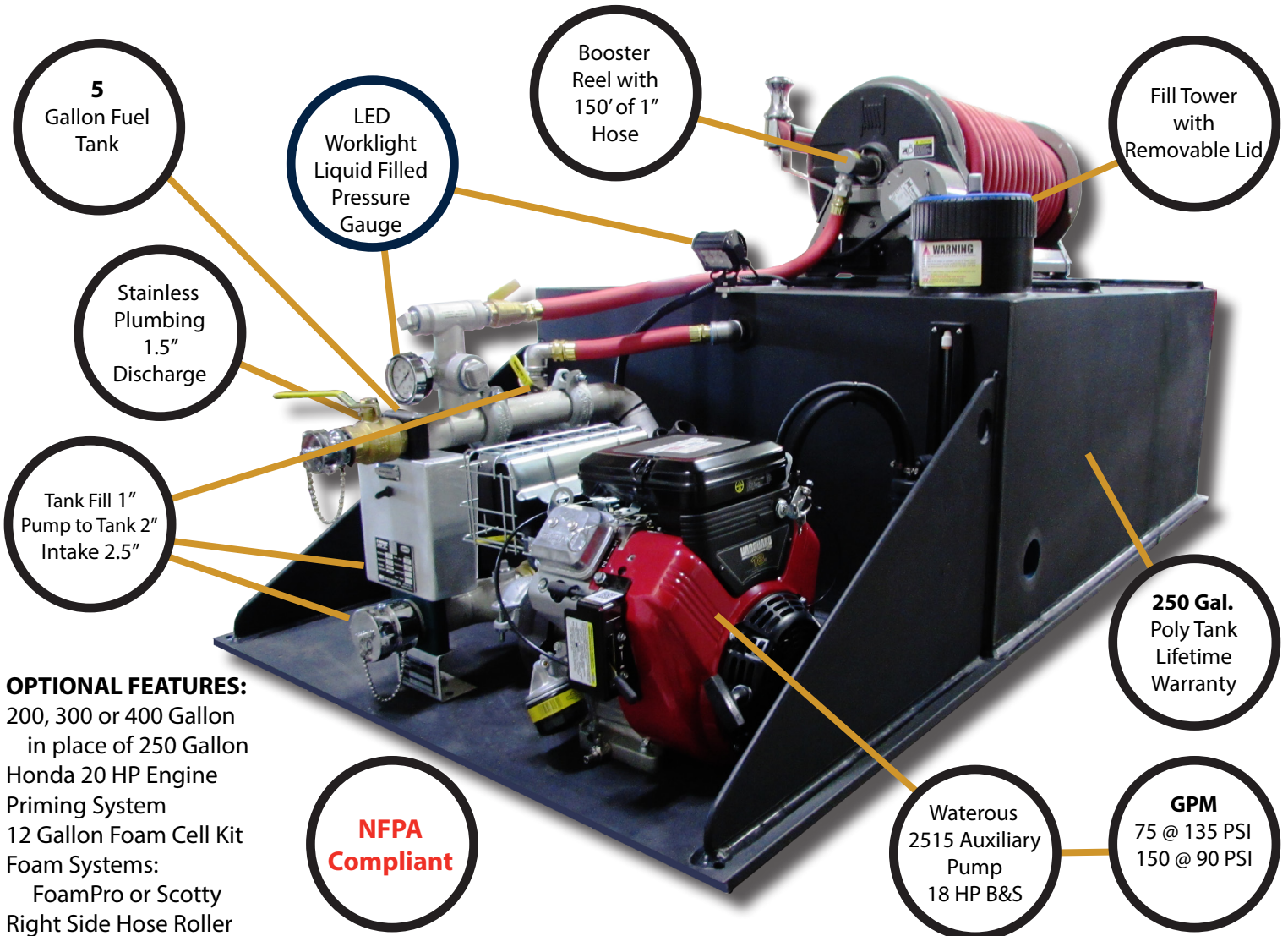

OPTIONAL FEATURES:

- 200, 300 or 400 Gallon in place of 250 Gallon
- Honda 20 HP Engine
- Priming System
- 12 Gallon Foam Cell Kit
- Foam Systems:
 - FoamPro or Scotty
- Right Side Hose Roller
- Preconnect Hosebed
- Additional Discharges
- Akron Brass Valves
- Pump Options:
 - Hale - Waterax - Darley
 - Diesel Engines

*Excludes shipping & taxes.

WILDLAND

Danko Emergency Equipment

302 E. 4th Street - Snyder, NE 68664

trucksales@danko.net

www.danko.net

866-568-2200

XL SKID UNIT

200 Gallon

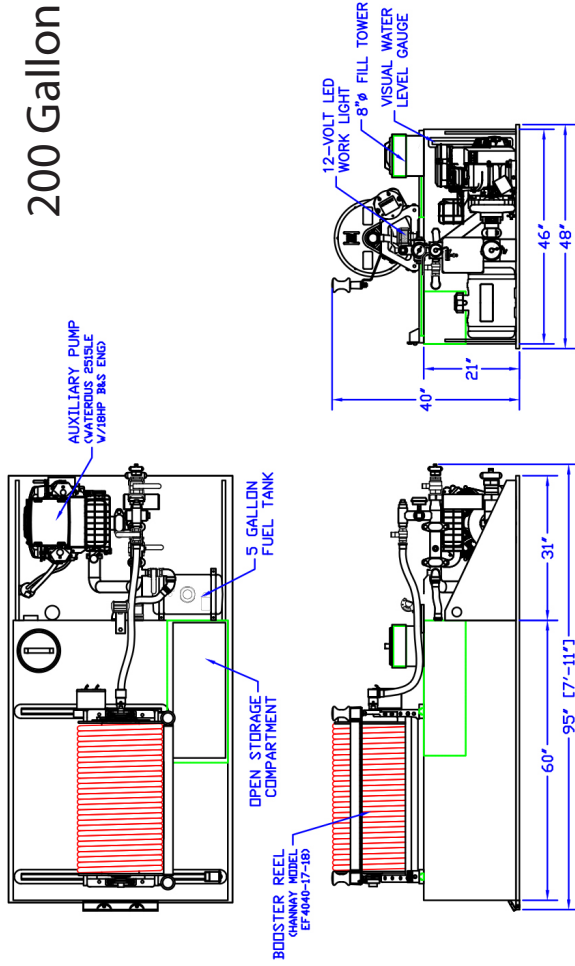

250 Gallon

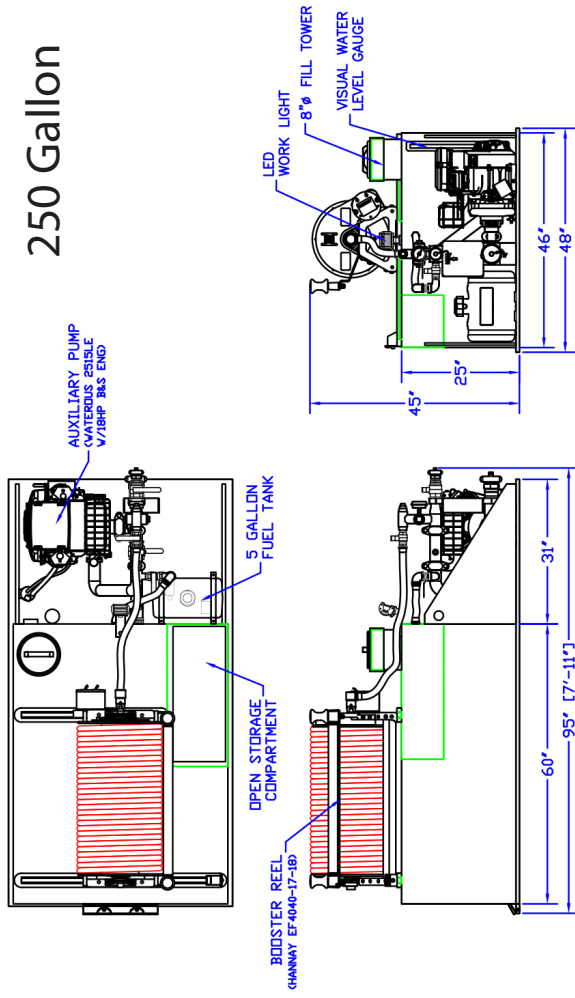

300 Gallon

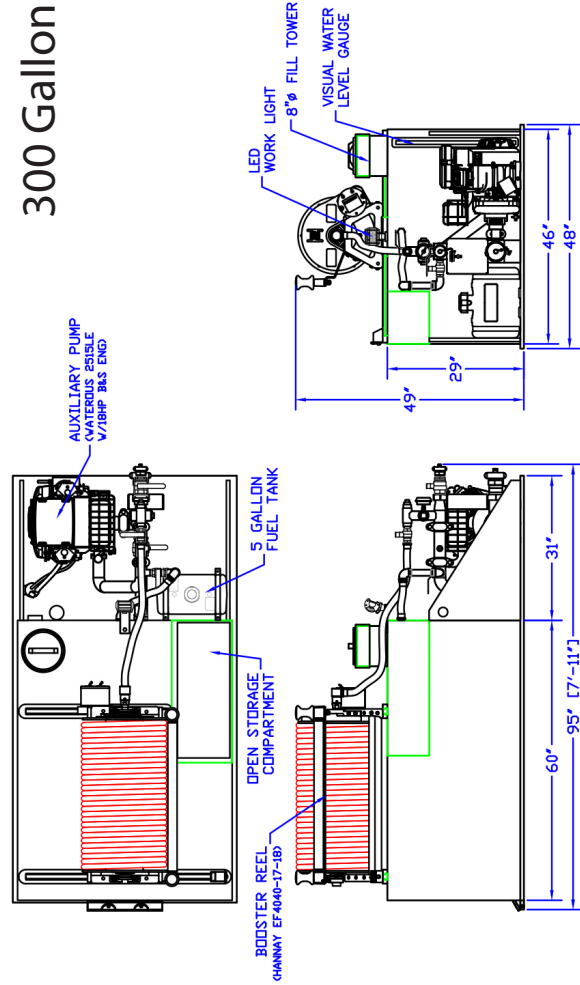

400 Gallon

